



CN 110791227 B  
2021.05.28

201911192162.9			
2019.11.28			(2006.01)
			(2006.01)
			(2006.01)
CN 110791227 A			(2006.01)
2020.02.14			(2006.01)
			(2006.01)
453007	46		(2006.01)

( ) 41139

书2 书4 7

100	20 30	5 10	3
6	2 8	4 6	1 5
	0.5 2	0.1 0.3	
0.5 2			

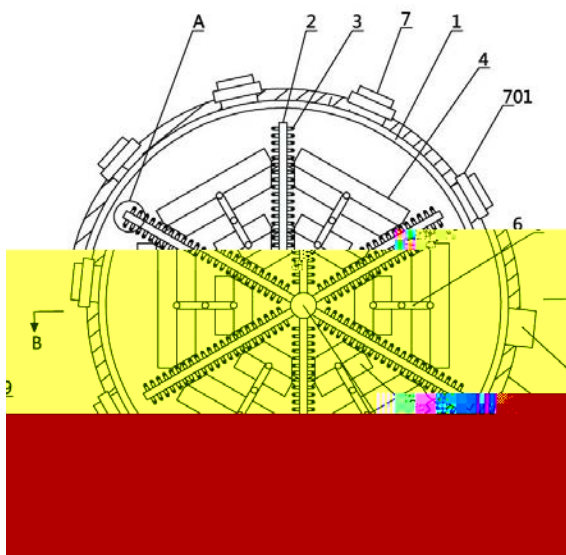

1.

50 70

0.1 0.3      3 6      2 8      4 6      100      20 30      5 10  
                    0.5 2                      1 5                      0.5 2

30 45

CN 110791227 B

10 30%

50 60

10 40% 50 60% 70 80%

70 80

1 1 7  
 9 7 701 9 1  
 8 8 801 1 11 1  
 10 10 1 10 3 3 301  
 2 2 2  
 4 5 4 402  
 402 401 4  
 4 4 401 6 10  
 2 4 4 5 502 5  
 502 501 5 2  
 5 501 6 10  
 6 16 16 15 15  
 1501 1501 10 14 1501  
 18 1501 18 19 1  
 1501 17 17 10 10 17  
 12 12 1 12 13  
 1  
 5 5 5 6 2 100 25  
 0.5 35 1 0.2  
 20%  
 1  
 1 11 55 7 701  
 7 1 80 7 701  
 701 1  
 7 701 1  
 70 7 7 1

701

1

				14		15		
1501	18	14	17	15			1501	
18		15		16			4	
	5		15		4		5	
1		17		4		5		
1			4	5	1		1	
						3		3

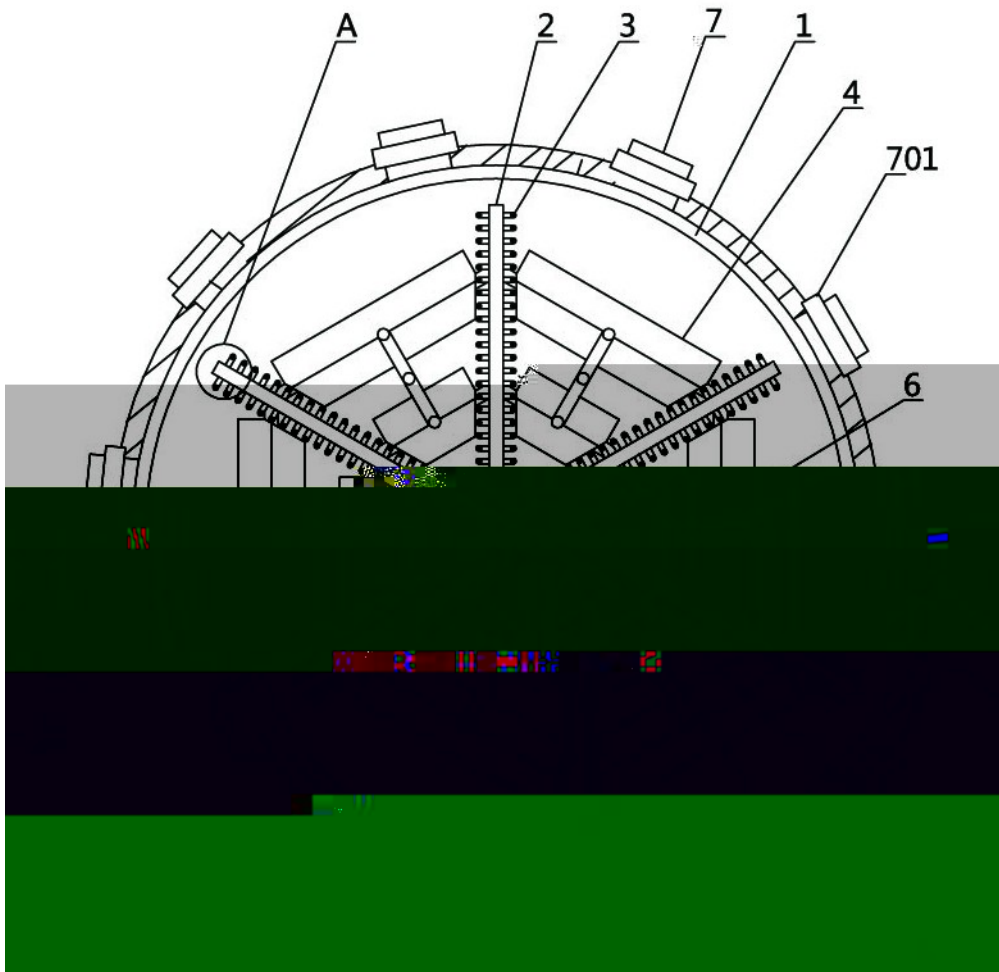



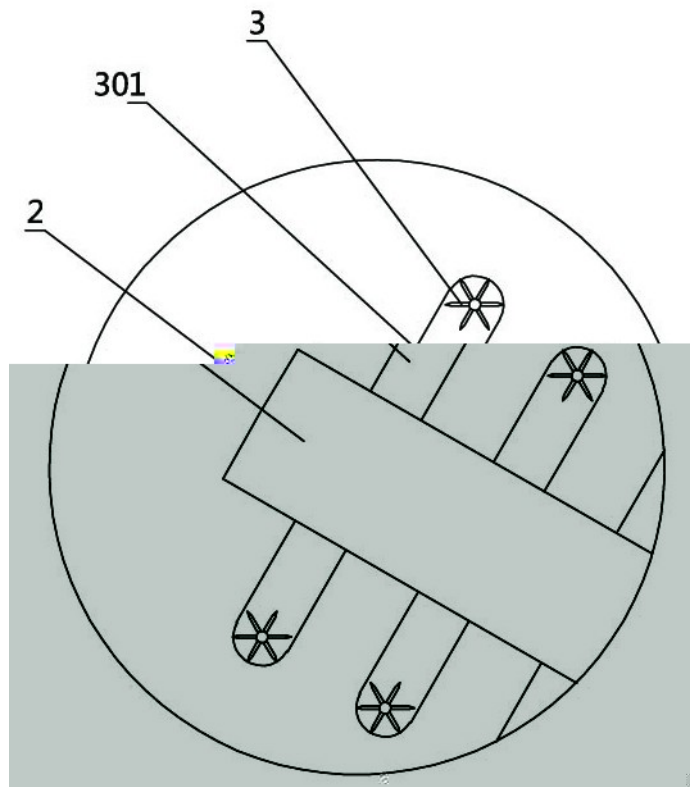

2

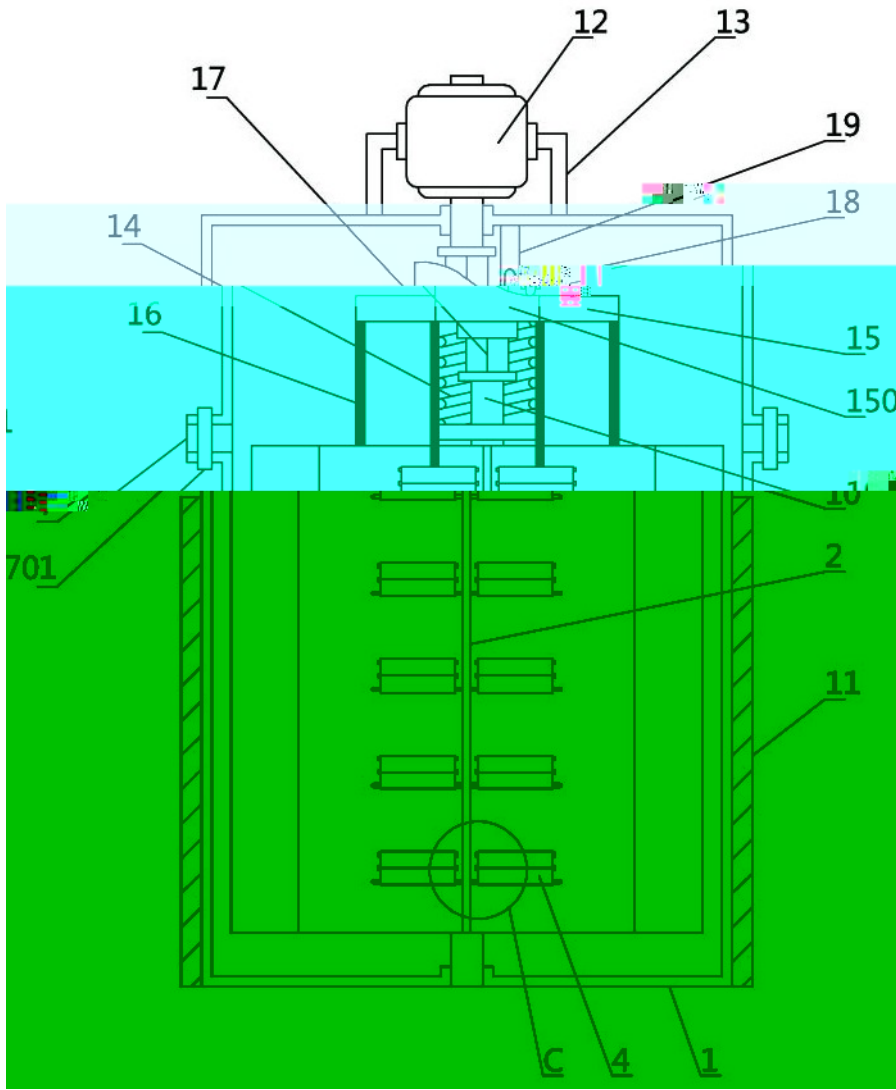

3

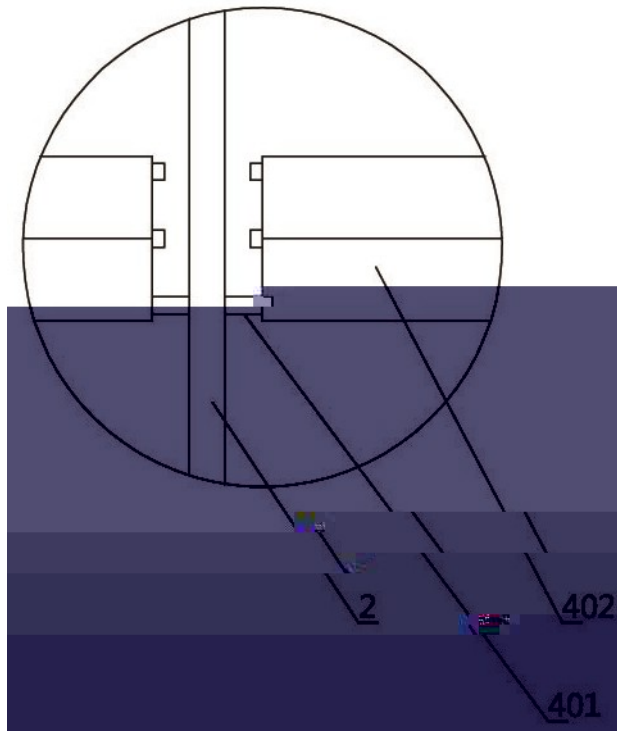

4

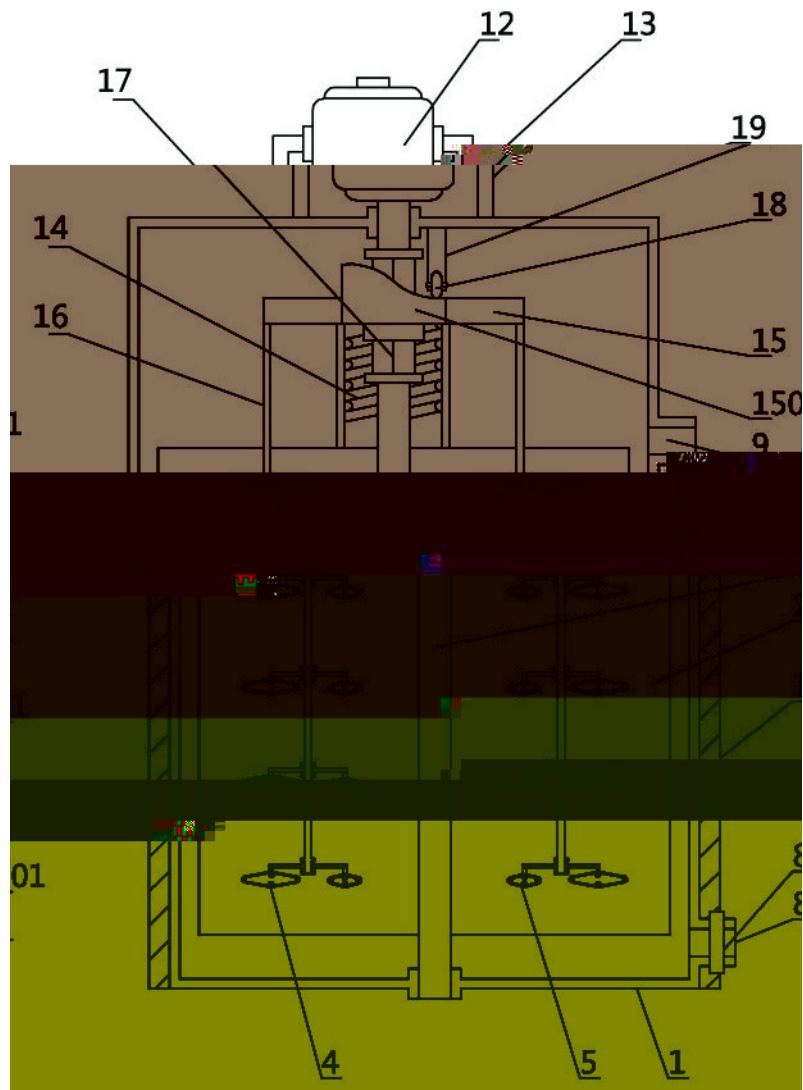

5

